

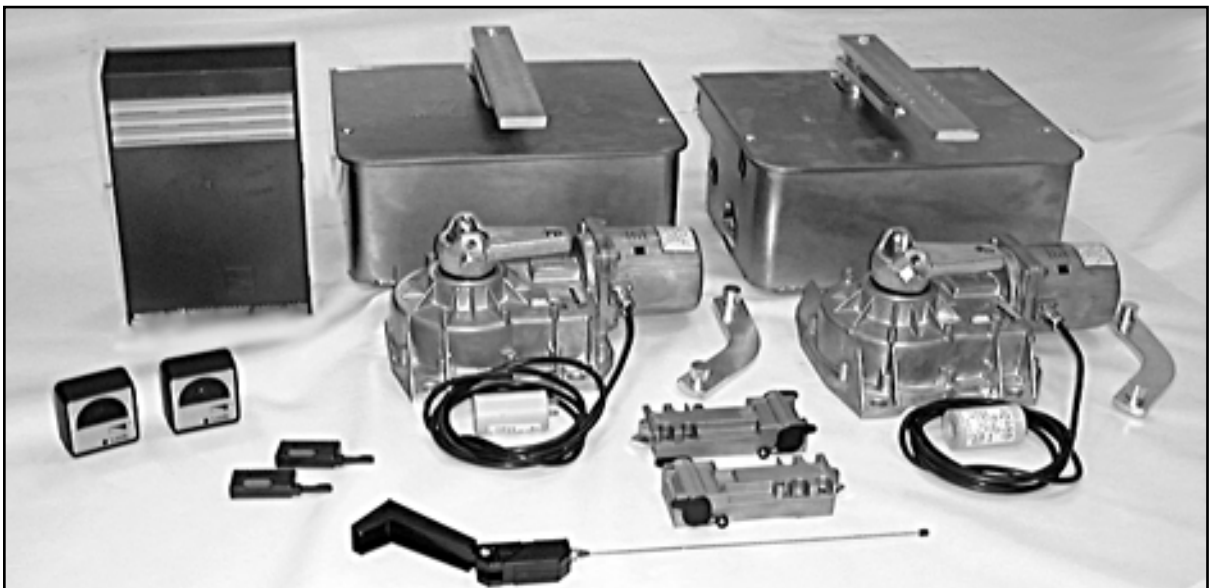

FROG KIT

*Installation Instructions
for a "Pair" of gates...*



THE FROG-P KIT CONSISTS OF:

- 2 X UNDERGROUND FOUNDATION CASINGS
- 2 X UNDERGROUND GATE MOTORS
- 1 X CONTROL PANEL
- 1 X RADIO FREQUENCY CARD
- 1 X TUNED ANTENNA
- 2 X REMOTE CONTROL TRANSMITTERS
- 1 X PAIR SAFETY BEAMS

INTRODUCTION

THESE INSTRUCTIONS WILL SHOW YOU HOW TO INSTALL A FROG UNDERGROUND GATE KIT TO A PAIR OF GATES.

PLEASE READ THESE INSTRUCTIONS AND DIAGRAMS CAREFULLY BEFORE STARTING ANY WORK.

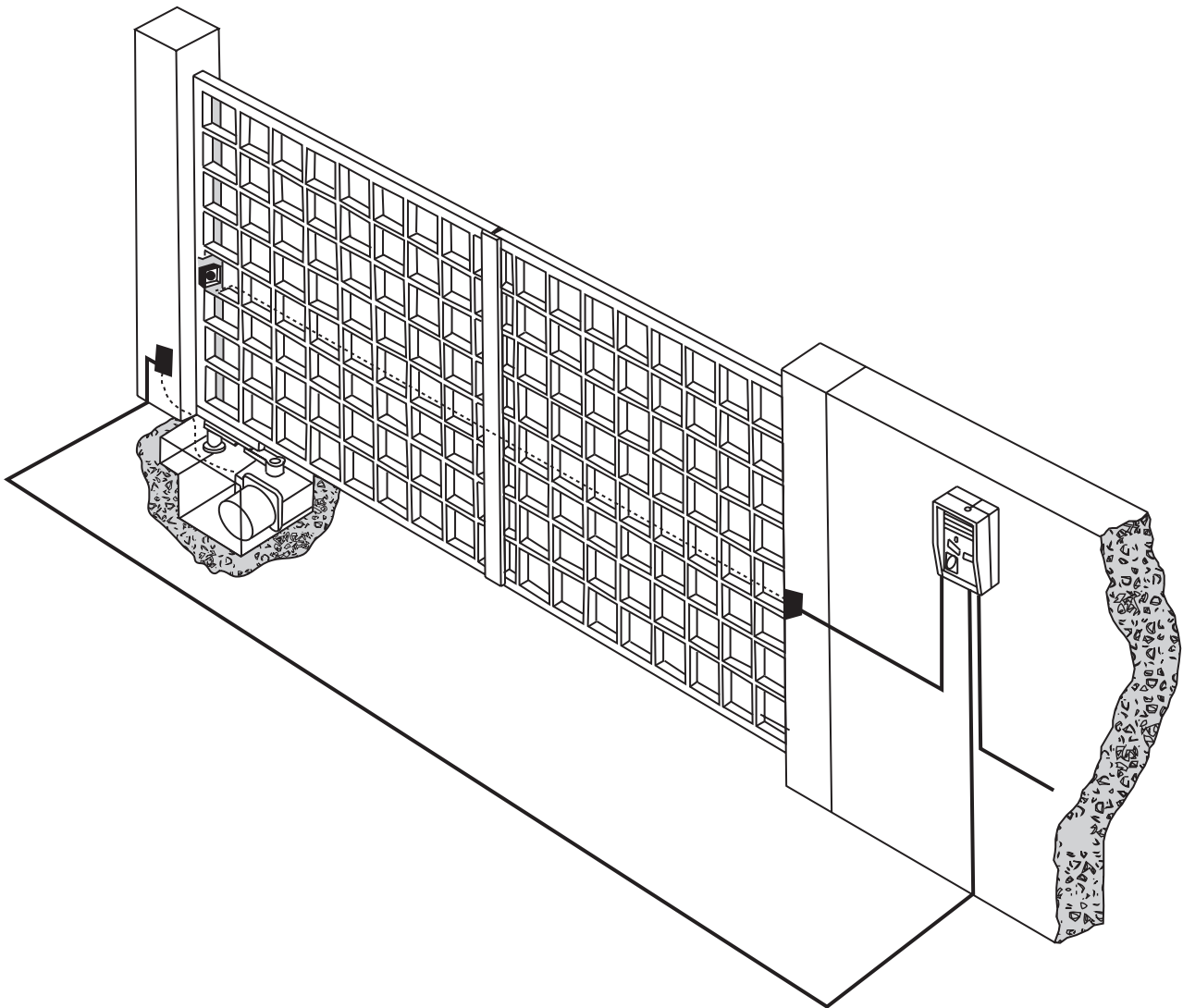

UNDER NO CIRCUMSTANCES SHOULD THIS EQUIPMENT BE OPERATED UNLESS FITTED TO A GATE.

FAILURE TO COMPLY WILL INVALIDATE THE GUARANTEE.

INSTALLATION INSTRUCTIONS

CONTENTS

1) Stage 1:- Civil & Mechanical Section	Page	
1.1	INSTALLATION OF THE FOUNDATION	3
1.2	BASIC CABLE LAYOUT	4
1.3	LOW VOLTAGE CABLE LAYOUT	4
1.4	INSTALLING THE MOTORS	5
1.5	HANGING THE GATES	5
1.6	FITTING THE GATE LOCK	6
2) Stage 2:- Wiring & Electrical		
2.1	FITTING THE CONTROL PANEL IN THE CASING	8
2.2	WIRING THE MOTORS	9
2.3	WIRING IN THE SAFETY PHOTOCELLS	10
2.4	INSERTING THE RADIO FREQUENCY CARD	10
2.5	WIRING IN THE TUNED ANTENNA	11
2.6	CODING THE REMOTE CONTROLS	11
2.7	POWERING UP THE CONTROL PANEL	11
3) Stage 3:- Commissioning the Control Panel		
3.1	INITIAL WIRING & CONTROL PANEL SETUP	13
3.2	OPENING & CLOSING THE GATES	14
3.3	CONTROL PANEL ADJUSTMENTS	15
3.4	AUTOMATIC CLOSE & SAFETY PHOTOCELLS	16
3.5	PROGRAMMING THE REMOTE CONTROLS TO THE CONTROL PANEL	17
4) Troubleshooting Guide		19
5) Technical Information		
5.1	TECHNICAL SPECIFICATIONS	21
5.2	CASING DIMENSIONS	21
5.3	OPERATING LIMITS	21
5.4	MOTOR TORQUE SETTINGS	22
5.5	ZA4 CONTROL PANEL DESCRIPTION	23
5.6	ZA4 WIRING DIAGRAM	25
5.7	CONTROL PANEL ADJUSTMENTS	26
5.8	ELECTRICAL CONNECTIONS	27
5.9	RE-HANDING THE MOTOR	28
6) Contact Information		31

STAGE 1

CIVIL & MECHANICAL SECTION

1.1 - Installation of Foundation Casings

THE UNDERGROUND CASING SHOULD BE CONCRETED IN THE GROUND. THE CASING SHOULD HAVE ADEQUATE DRAINAGE TO A SUITABLE SOAK AWAY. WHEN INSTALLING THE FOUNDATION CASING AS A GUIDE ALLOW APPROXIMATELY 100MM AROUND THE CASING AND 100MM UNDERNEATH THE CASTING FOR CONCRETE.

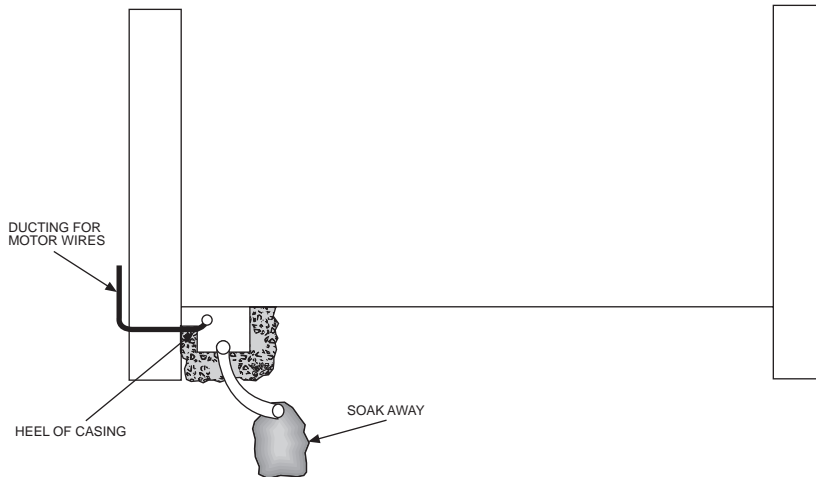

WHEN CONCRETING THE CASING IN PLACE, ENSURE THAT THE HEEL OF THE CASING IS PACKED WITH CONCRETE AS THIS WHERE ALL OF THE WEIGHT OF THE GATE WILL SIT. ALLOW AT LEAST TWO DAYS FOR THE CONCRETE TO GO OFF.

WHEN SETTING THE CASING IN PLACE ENSURE THAT THE TOP HINGE PIN IS PLUMB IN LINE WITH THE HINGE PIVOT IN THE CASING. THE CENTRE OF PIVOT IS 65mm STANDOFF FROM THE BACK OF THE CASING. THE CASING SHOULD BE SET PERFECTLY SQUARE AND LEVEL AND PROTRUDING APPROXIMATELY 3mm FROM GROUND LEVEL.

WHEN CONCRETING THE CENTRE STOP IN PLACE ENSURE THAT IT DOES NOT PROTRUDE MORE THAN 65mm TO 70mm FROM GROUND LEVEL ANYMORE AND IT MAY DAMAGE THE UNDERSIDE OF LOW VEHICLES.

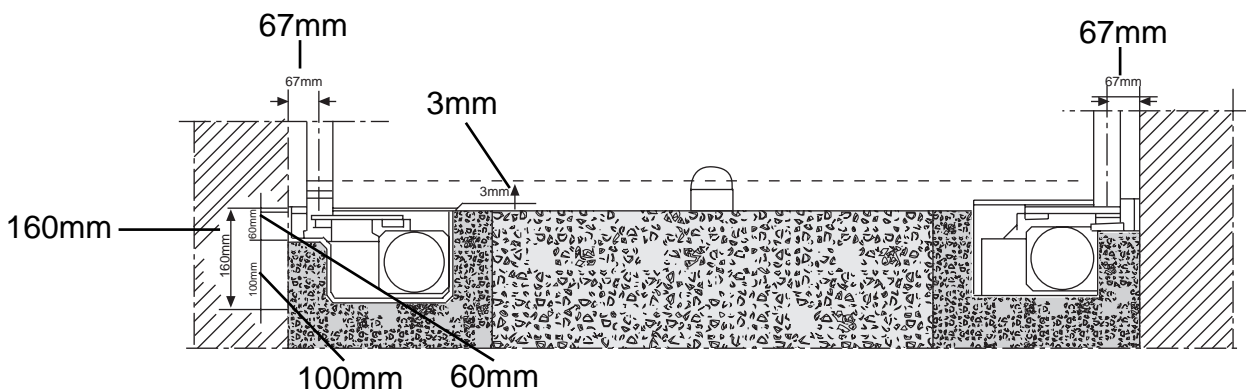

1.2 - Basic Cable Layout

THIS DIAGRAM DETAILS THE BASIC CABLE LAYOUT FOR A PAIR OF MOTORS.

THE POWER SUPPLY TO THE CONTROL PANEL SHOULD BE LIVE AND PROTECTED IN ACCORDANCE WITH THE 16TH EDITION ELECTRICAL REGULATIONS. THE SUPPLY SHOULD BE RATED AT A MINIMUM OF 6 AMPS. WHEN INSTALLING WIRES OUTDOORS THE CABLE APPROACH TO ALL DEVICES MUST BE FROM BELOW TO CREATE A "DRIP-LOOP" AND THEREBY AVOID UNNECESSARY WATER INGRESS.

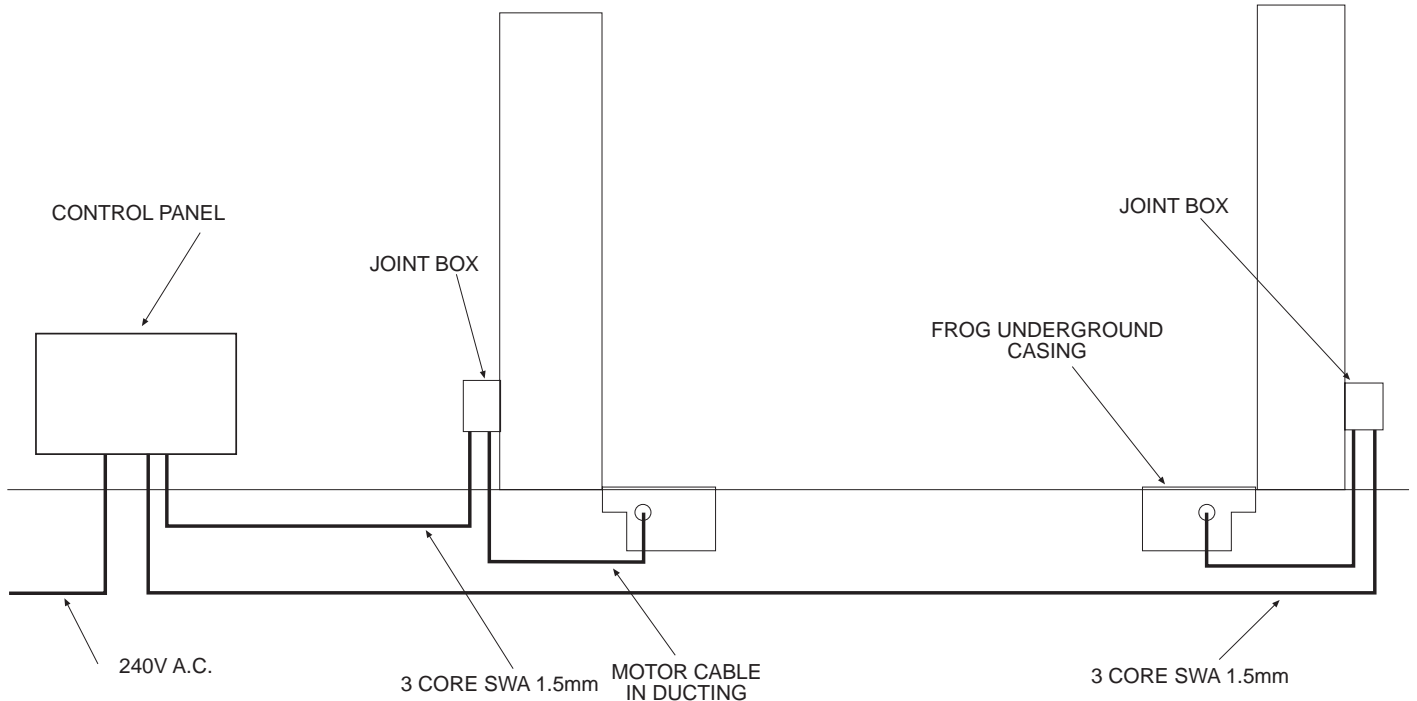

1.3 - Low Voltage Cable Layout

THIS DIAGRAM DETAILS THE BASIC CABLE LAYOUT FOR A PAIR OF MOTORS.

THE POWER SUPPLY TO THE CONTROL PANEL SHOULD BE LIVE AND PROTECTED IN ACCORDANCE WITH THE 16TH EDITION ELECTRICAL REGULATIONS. THE SUPPLY SHOULD BE RATED AT A MINIMUM OF 6 AMPS. WHEN INSTALLING WIRES OUTDOORS THE CABLE APPROACH TO ALL DEVICES MUST BE FROM BELOW TO CREATE A "DRIP-LOOP" AND THEREBY AVOID UNNECESSARY WATER INGRESS.

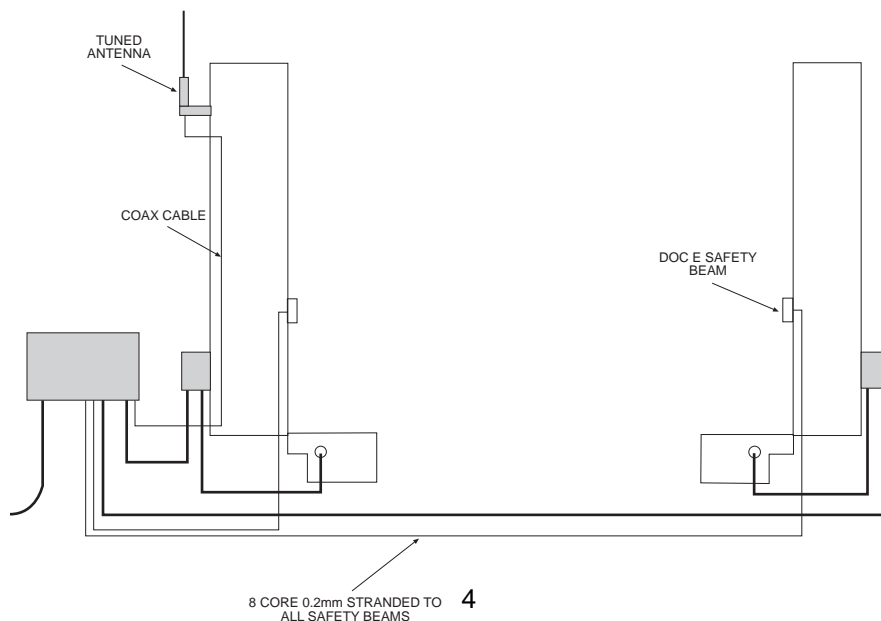

1.4 - Installing the Motors

INSERT THE MOTORS ONTO THE STUDS IN THE CASING. IF THE GATES ARE HUNG BETWEEN THE POSTS AND THE GATES OPEN INWARDS THE MOTORS NEED TO BE POINTING INTO THE PROPERTY.

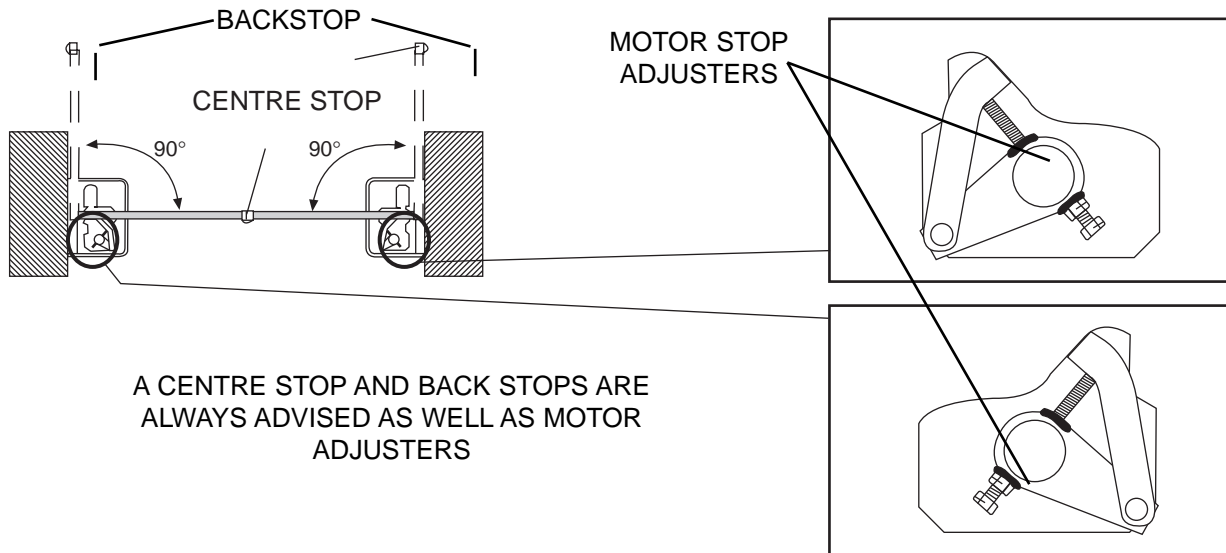

IF THE GATES ARE HUNG ON THE BACK OF THE POSTS THE MOTORS NEED TO BE POINTING TOWARDS EACH OTHER.

1.5 - Hanging the Gates

BEFORE ATTACHING THE GATES ENSURE THAT THE GATE PIVOT POINT ARE ADEQUATELY GREASED.

WHEN HANGING THE GATE ENSURE THAT THEY ARE SQUARE AND LEVEL BEFORE WELDING THE GATE TO THE FROG SHOE. WHEN WELDING THE GATE TO THE FROG SHOE **DO NOT** WELD OVER THE THREADED HOLES IN THE SHOE.

WHEN HANGING WOODEN GATES IT IS NECESSARY TO CREATE A U-SHAPED CARRYING SHOE IN MILD STEEL WHICH CAN BE WELDED TO THE TOP SURFACE OF THE FROG SHOE. THEN THE WOODEN GATE CAN BE BOLTED INTO POSITION WITH THE U-SHAPED CARRYING SHOE CLAMPING TO THE BOTTOM OF THE GATE.

1.6 - Fitting the Gate Lock

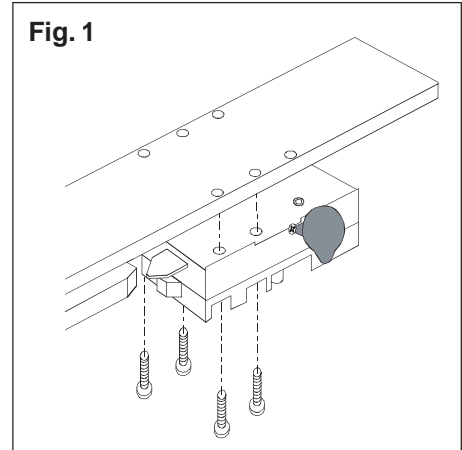
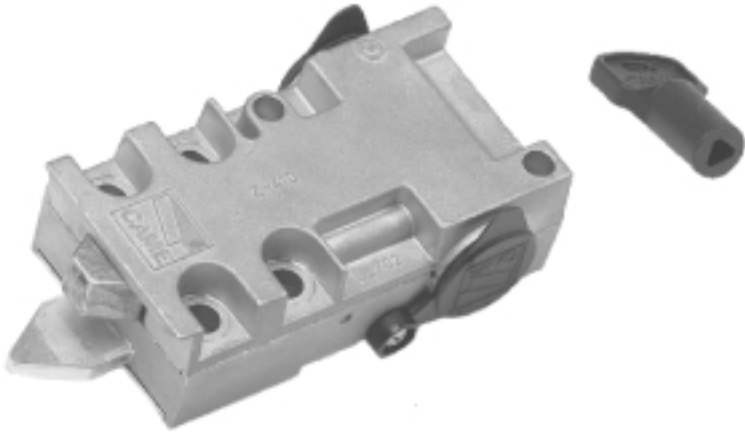

Secure the unlocking device to the FROG shoe with the 4 allen bolts provided.

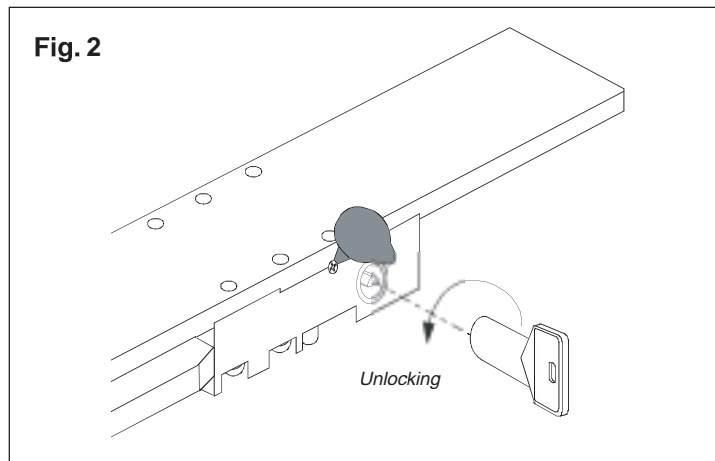

To release the gate, raise the protective cap, insert the three sided key and turn it to activate the mechanism. Simultaneously push and/or pull the gate. Remove the key and replace the protective cap.

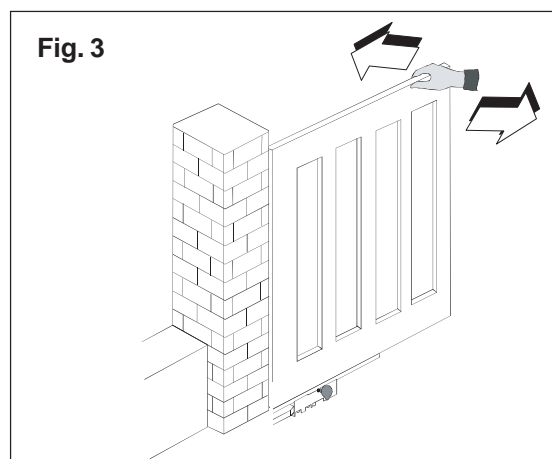

To re-engage the gate, reposition the gate and the mechanism will automatically engage it.

END OF INSTALLATION

STAGE 1

BEFORE STARTING STAGE 2 - Wiring & Electrical
PLEASE CHECK THAT YOU HAVE CORRECTLY:

	Ref	Page
1. INSTALLED THE FOUNDATION CASING	1.1	3
2. PREPARED THE CABLING CORRECTLY	1.2	4
	1.3	4
3. INSTALLED THE MOTORS CORRECTLY	1.4	5
4. HUNG THE GATES CORRECTLY	1.5	5
5. CHECKED THE MANUAL RELEASE SYSTEM	1.6	6

NOW STAGE 1 IS FULLY COMPLETED YOU ARE READY TO
BEGIN STAGE 2 OF YOUR FROG AUTOMATION KIT
INSTALLATION

STAGE 2 - WIRING & ELECTRICAL

2.1 - Fitting the Control Panel in the Casing

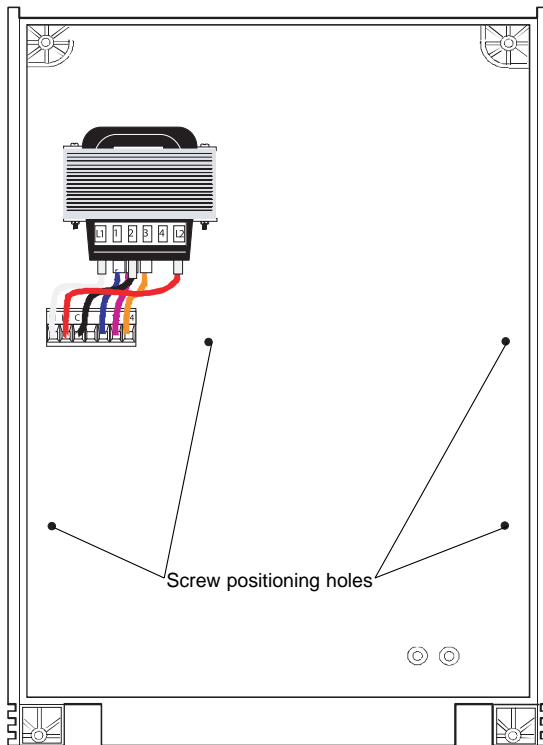

Securely fasten the control panel PCB to the casing with the screws supplied.

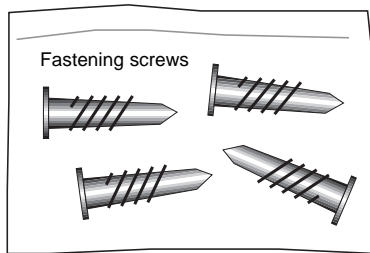

Green connector point

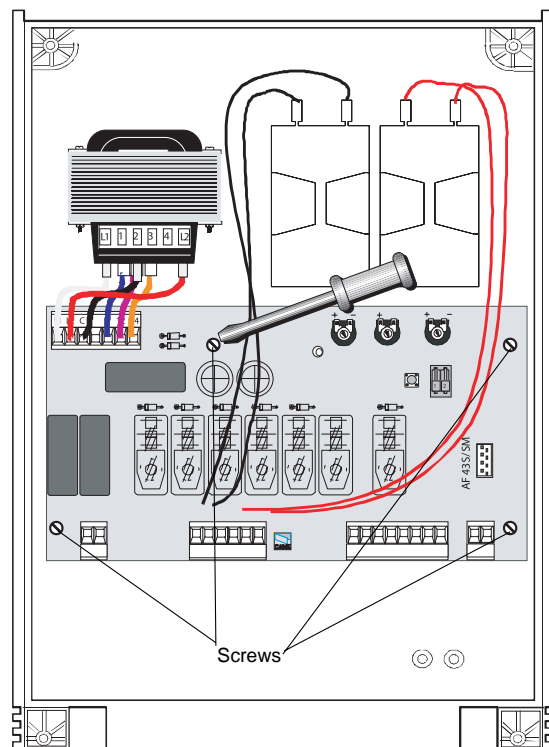
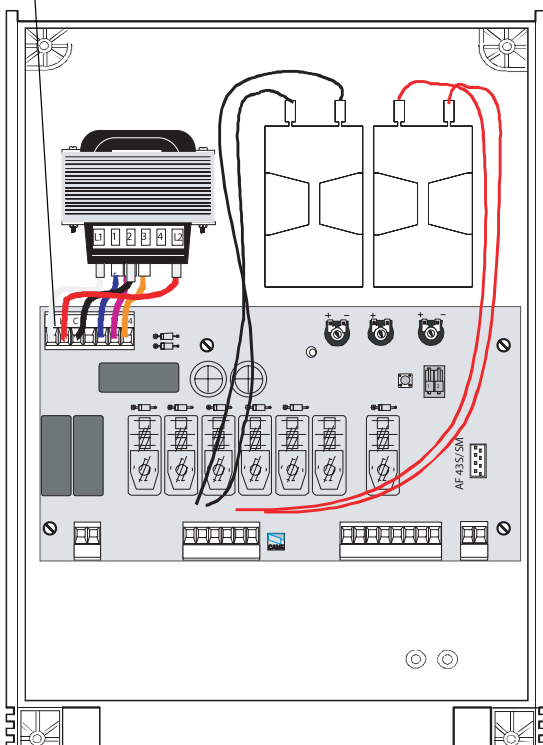

Plug the green connector from the transformer to the PCB ensuring that it connects the correct way.

NB FROG Series Motors: connect the black wires coming out of the board to one capacitor and the red wires to the other.

2.2 - Wiring the Motors

THE FROG MOTORS ALWAYS COME PREWIRED AND THE CONNECTIONS TO THE MOTOR SHOULD BE MADE IN THE JUNCTION BOXES AT THE BASE OF THE GATE POST (I.E OUT OF THE GROUND OR FOUNDATION CASING) AS SHOWN IN FIG 3.

UNDER NO CIRCUMSTANCES MUST THE MOTOR BE DISCONNECTED FROM THE GEARBOX AS THIS WILL INVALIDATE THE WARRANTY.

WHEN CONNECTING THE MOTORS TO THE CONTROL PANEL THE BLUE WIRE ON THE MOTOR IS THE COMMON WIRE AND IS ALWAYS TO THE "W" ON THE TERMINAL STRIP IN THE CONTROL PANEL. THE BROWN AND BLACK WIRES ARE THE MOTOR DIRECTIONS AND ARE CONNECTED TO "U+V" FOR MOTOR 1 OR "X+Y" FOR MOTOR 2.

ENSURE BOTH MOTORS ARE ADEQUATELY EARTHED.

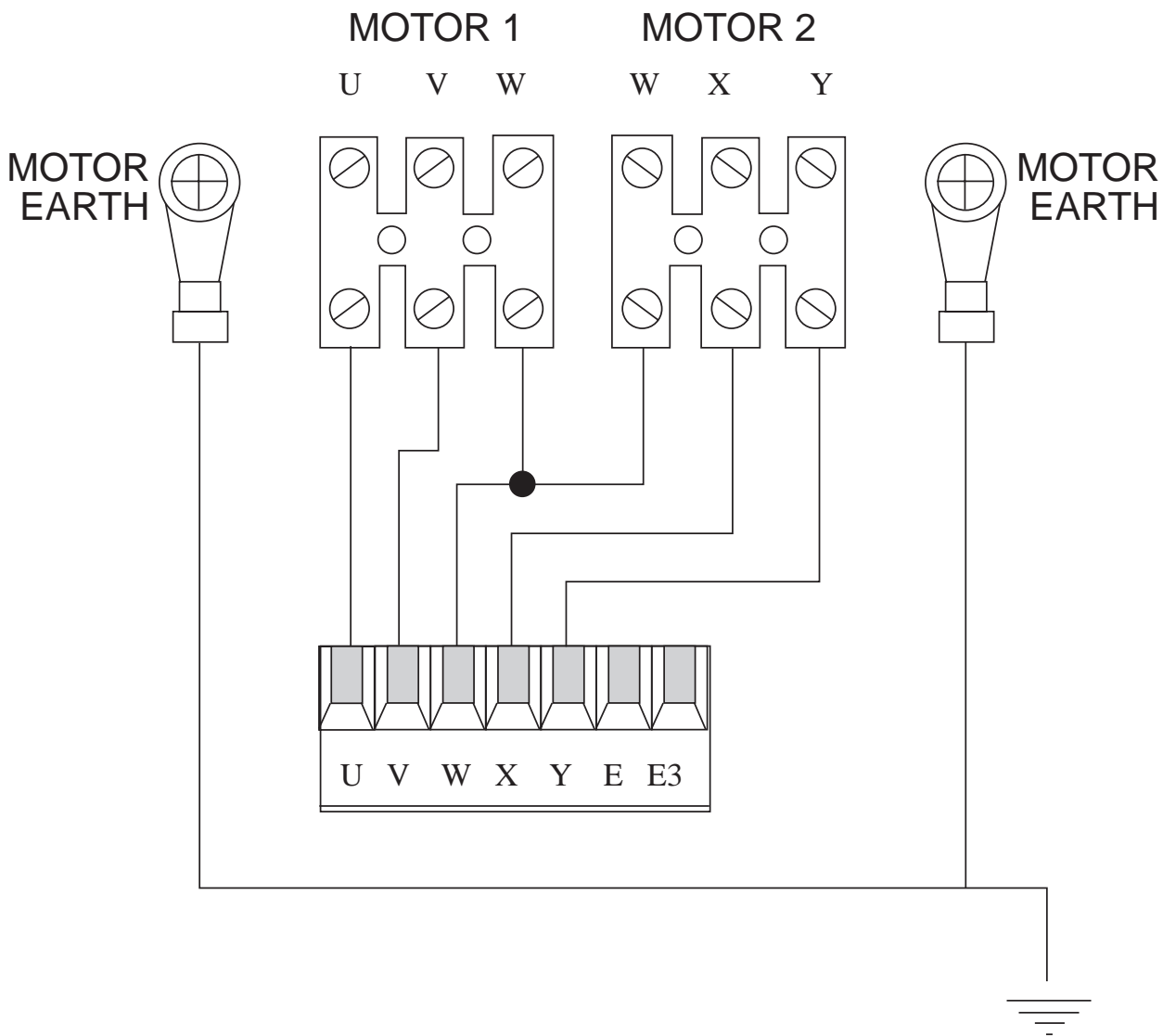

2.3 - Wiring in the Safety Photocells

SAFETY BEAMS SHOULD BE FITTED APPROXIMATELY
15 INCHES FROM GROUND LEVEL

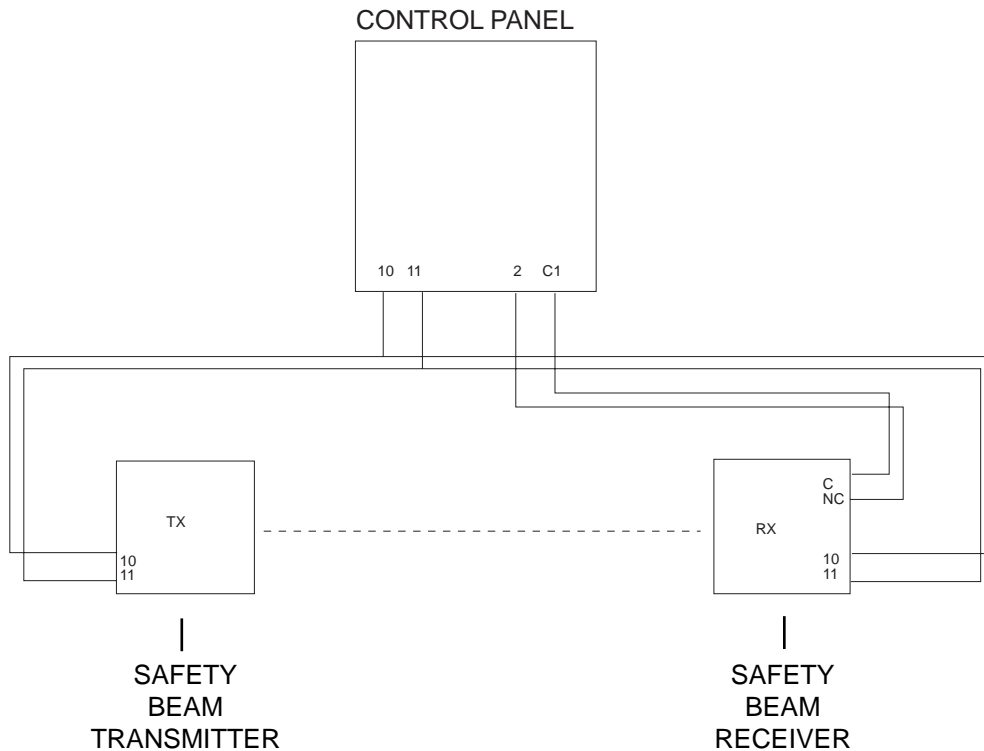

IF FITTING A SECOND ARC LINE SET OF SAFETY BEAMS THEN C & NC MUST
BE WIRED IN "SERIES"

2.4 - Inserting the Radio Frequency Card

SAFETY BEAMS SHOULD BE FITTED APPROXIMATELY
15 INCHES FROM GROUND LEVEL

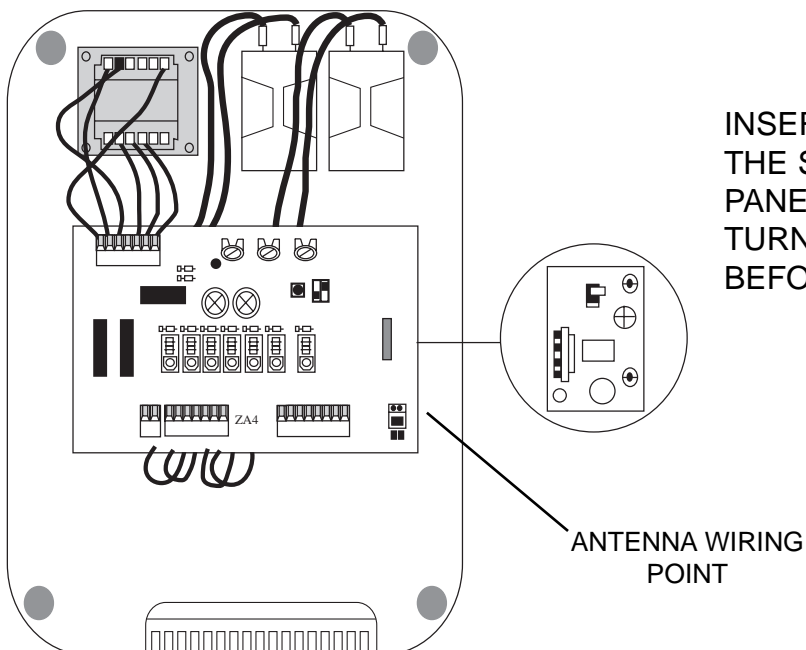

INSERT THE RADIO FREQUENCY CARD INTO
THE SMALL SOCKET ON THE CONTROL
PANEL (ENSURE THAT THE POWER IS
TURNED OFF TO THE CONTROL PANEL
BEFORE INSERTING THE FREQUENCY CARD)

2.5 - Wiring in the Tuned Antenna

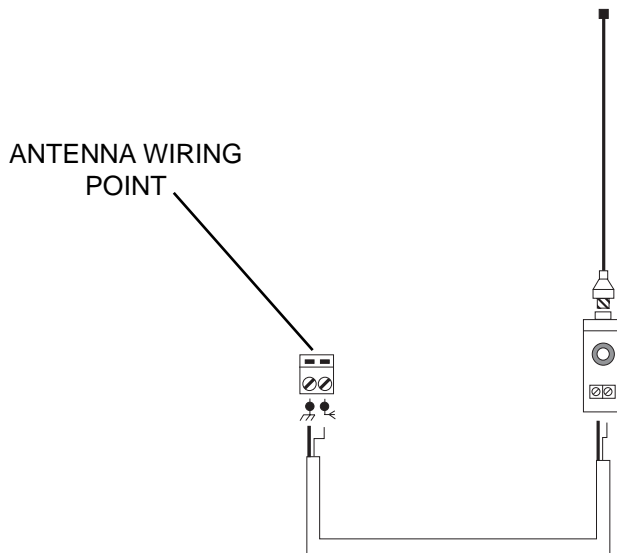

2.6 - Coding the Remote Controls

1. REMOVE THE BATTERY COVER & CASING OF THE REMOTE CONTROL HANDSET TO REVEAL THE DIAGRAM BELOW

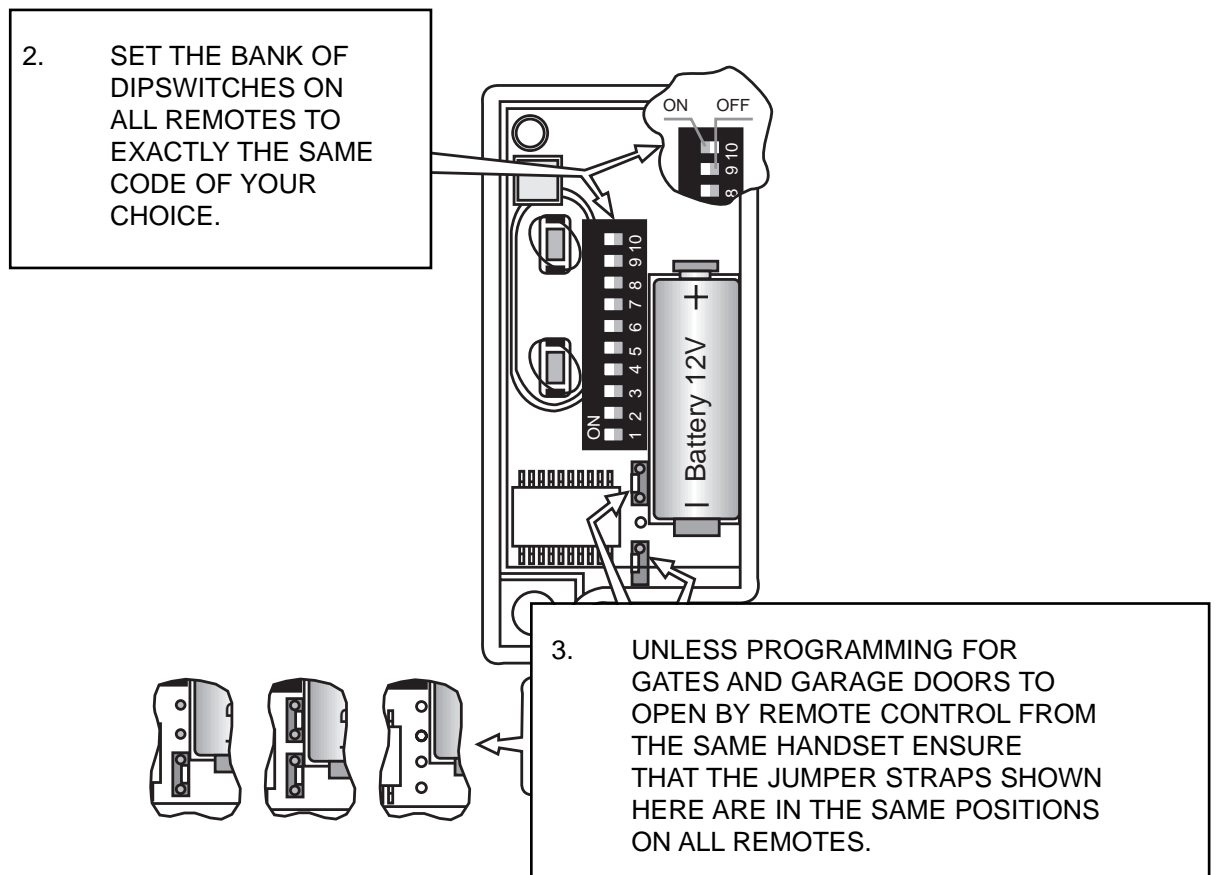

2.7 - Powering up the Control Panel

CONNECT PROTECTED MAINS POWER TO TERMINALS L1 + L2 IN THE CONTROL PANEL (L2 BEING LIVE!). ENSURE THAT THE CONTROL PANEL IS ADEQUATELY EARTHED.

END OF INSTALLATION

STAGE 2

BEFORE STARTING STAGE 3 -
Commissioning the Control Panel

PLEASE CHECK THAT YOU HAVE CORRECTLY:

	Ref	Page
1. FITTING THE CONTROL PANEL IN THE CASING 2.1	2.1	8
1. WIRED THE MOTORS AS SHOWN (Fig 7)	2.2	9
2. WIRED IN THE SAFETY PHOTOCELLS AS SHOWN (Fig 8)	2.3	10
3. INSERTED THE RADIO FREQUENCY CARD AS SHOWN (Fig 9)	2.4	10
4. WIRED IN THE TUNED ANTENNA CODED AS SHOWN (Fig 10)	2.5	11
5. PROGRAMMED THE REMOTE CONTROLS AS SHOWN (Fig 11)	2.6	11
6. POWERED UP THE CONTROL PANEL	2.7	11

NOW STAGE 2 IS FULLY COMPLETED YOU ARE READY TO
BEGIN STAGE 3 OF YOUR FROG AUTOMATION KIT
INSTALLATION

STAGE 3

COMMISSIONING THE CONTROL PANEL

3.1 - Initial Wiring & Control Panel Setup

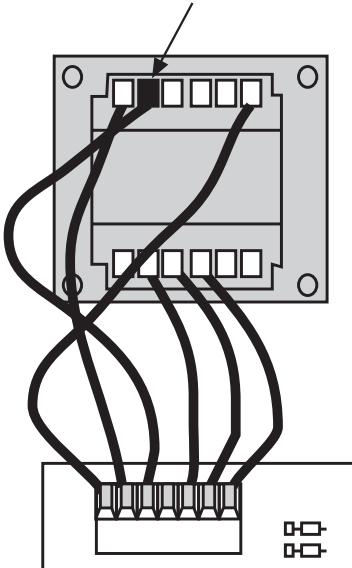

1. CONNECT POWER TERMINALS L1 - L2 AND A SUITABLE EARTH (L2 BEING LIVE!)
2. SELECT THE MOTOR POWER SETTING ON THE TRANSFORMER TO LEVEL 1 FOR COMMISSIONING

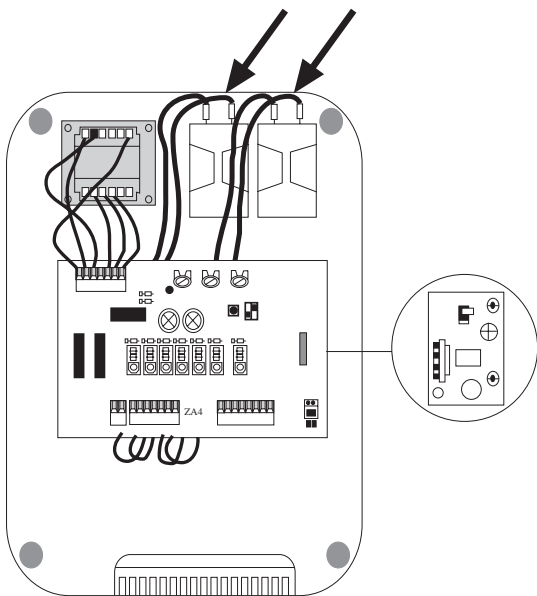

3. INSERT THE 'START-UP' CAPACITORS INTO THE CONTROL PANEL. THE TWO BLACK WIRES FOR MOTOR 1 AND THE TWO RED WIRES FOR MOTOR 2.
4. ENSURE THAT THE MOTORS ARE ADEQUATELY EARTHED.

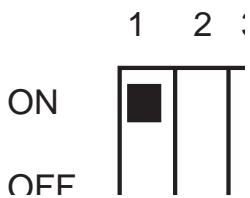

5. SELECT DIPSWITCHES 1 & 2 OFF FOR COMMISSIONING

6. ENSURE HARD WIRE LINK IS FITTED BETWEEN TERMINALS 1 & 2 AND 2 & C1

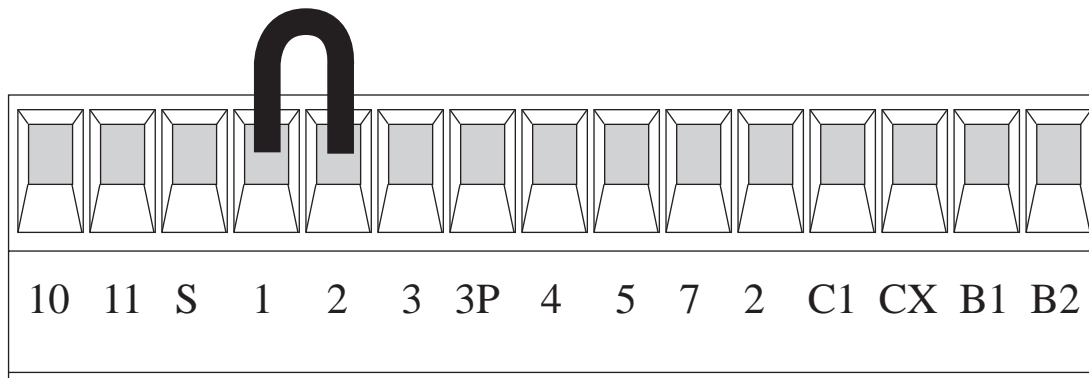

3.2 - Opening & Closing the Gates

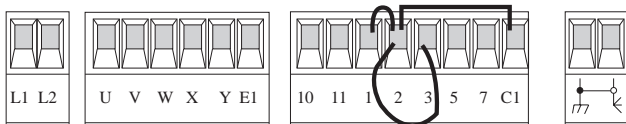

1. MOMENTARILY PULSE TERMINALS 2 & 3 WITH A PIECE OF WIRE TRAILING FROM TERMINAL 2 AND MOMENTARILY TOUCHING TERMINAL 3.

THE GATES SHOULD START TO OPEN. IF THEY START TO CLOSE TURN THE POWER OFF TO THE CONTROL PANEL AND CHANGE AROUND EITHER U-V (MOTOR 1) OR X-Y (MOTOR 2) TO CHANGE THE MOTOR DIRECTION.

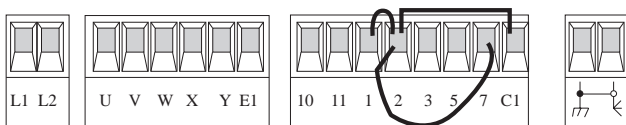

2. ONCE YOU HAVE PROVED THE MOTOR DIRECTION USE TERMINALS 2 & 7 TO OPEN AND CLOSE THE GATES WITH A TRAILING WIRE ONCE AGAIN INTO TERMINAL 2, MOMENTARILY TOUCHING TERMINAL 7.

3.3 - Control Panel Adjustments

1. TO DELAY ONE GATE LEAF, ADJUST POTENIOMETER TR2M TO DELAY THE CLOSIN OF GATE NO. 2 IN THE CLOSING CYCLE.

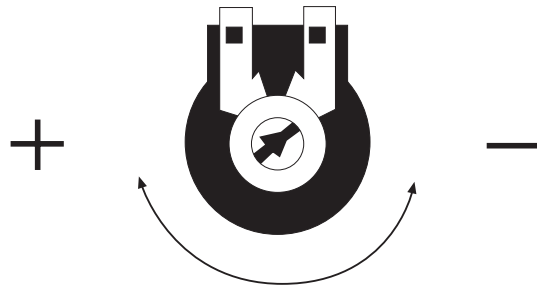

TRIMMER TR2M

2. TO SET THE TOTAL RUNNING TIME OF THE MOTORS, ADJUST POTENIOMETER TL TO ALLOW THE MOTORS TO RUN FOR A FURTHER 5-7 SECONDS AFTER THE MOVEMENT CYCLE HAS BEEN COMPLETED (I.E FULLY OPEN OR FULLY CLOSED).

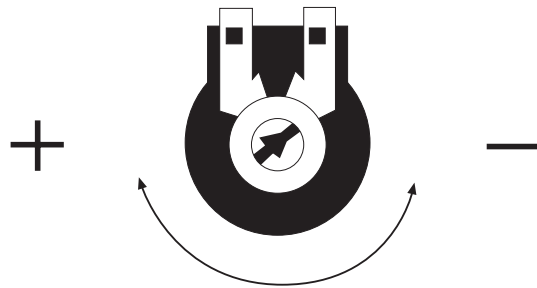

TRIMMER TL

3. CHECK THE SENSITIVITY OF THE GATES BY TRYING TO PHYSICALLY STOP THE GATE AND ADJUST THE POWER SETTINGS ON THE TRANSFORMER ACCORDINGLY. IF MORE POWER IS NEEDED FOR HEAVIER GATES THEN SWITCH OFF POWER AND MOVE TRANSFORMER WIRE UP TO SETTING 2. FOR RECHECKING SENSITIVITY, REPEAT PROCESS UP TO 3 OR 4 IF EVEN MORE POWER IS NEEDED.

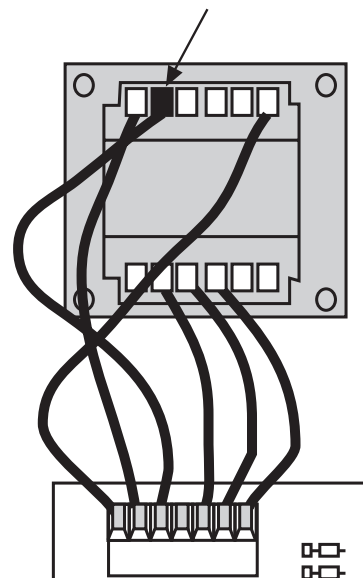

3.4 - Automatic Close & Activating Safety Photocells

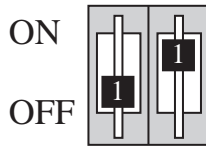

1. TO SELECT AUTOMATIC CLOSING, SELECT DIPSWITCH 2 **ON**.

SET THE AUTOMATIC CLOSING TIME BY ADJUSTING POTENTIOMETER TCA

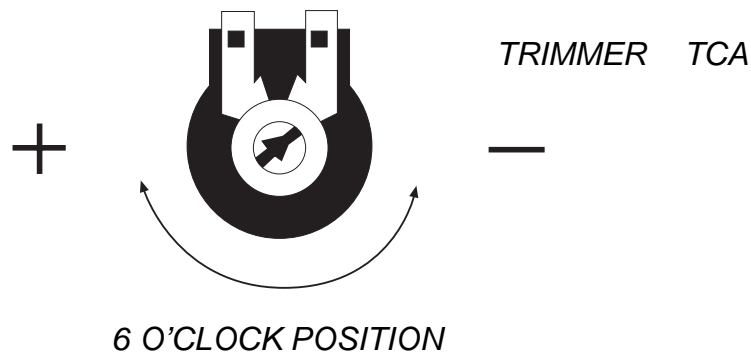

FULLY ANTI-CLOCKWISE WILL APPROX. AUTOMATICALLY CLOSE THE GATES AFTER 10 SECONDS AND FULLY CLOCKWISE WILL APPROX. CLOSE THE GATES AFTER 80 SECONDS. A SENSIBLE SETTING IS ABOUT HALWAY (I.E 6 O'CLOCK POSITION) WHICH WILL AUTOMATICALLY CLOSE THE GATES AFTER APPROX. 30 SECONDS.

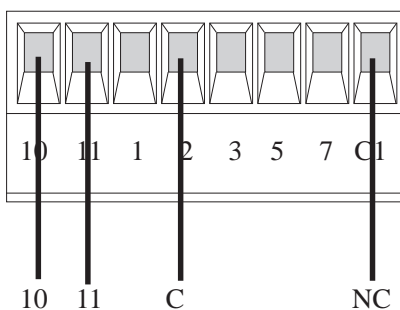

2. FOR RE-OPENING DURING CLOSING. REMOVE HARD WIRE LINK BETWEEN 2 & C1 AND INSERT SAFETY BEAM WIRES AS SHOWN.

3.5 - Programming the Remote Controls to the Control Panel

To use the remote control system, proceed as follows:

- A) Turn power OFF and insert AF radio frequency board then turn power back on
- B) Code the transmitter. See the relevant instruction sheet (See Fig 11)
- C) To store the code on the circuit board Proceed as follows:

Press and hold down the programming button on the radio receiver card (the signal LED will start to flash)

At the same time transmit on the top button of your remote control; keep both the top button and the yellow receiver button pressed until the LED stops flashing and remains on constant. It will then go out to indicate that the code has been successfully stored.

- N.B. If you wish to change the code on your transmitter in the future, simply repeat the procedure above with all the remotes on the installation.

WARNING: *Disconnect the power supply from the control board before inserting OR removing the AF radio-frequency card from the socket.*

END OF INSTALLATION

STAGE 3

PLEASE CHECK THAT YOU HAVE CORRECTLY:

	Ref	Page
1. SET POWER SETTING, INSERTED MOTOR CAPACITORS, SET DIPSWITCHES FOR COMMISSIONING, ENSURE WIRE LINK IS FITTED BETWEEN TERMINALS 1 & 2 AND 2 & C1	3.1	12
2. SET THE OPENING AND CLOSING TIMES FOR GATES	3.2	13
3. ADJUSTED THE CONTROL PANEL	3.3	14
4. IF REQUIRED, ACTIVATED AUTOMATIC CLOSING AND SAFETY PHOTOCELLS	3.4	15
5. PROGRAMMED THE REMOTE TO THE CONTROL PANEL	3.5	16

4 - TROUBLESHOOTING GUIDE

A multimeter will be needed

PROBLEM	SOLUTION
GATE WILL NOT RESPOND WHEN GIVEN A COMMAND	<ol style="list-style-type: none">1. CHECK POWER SUPPLY TO THE CONTROL PANEL.2. CHECK CONTROL PANEL FUSES.3. CHECK HARD WIRE LINK FITTED BETWEEN TERMINALS 1 & 2.4. CHECK THAT CAPACITORS ARE FITTED AND WIRED CORRECTLY.
GATES ARE OPEN BUT WILL NOT CLOSE AND GREEN LED IS FLASHING	<ol style="list-style-type: none">1. CHECK SAFETY BEAMS ARE WIRED CORRECTLY. (IF MORE THAN ONE SET OF BEAMS ARE FITTED THEY MUST BE WIRED IN SERIES.)2. CHECK THAT THERE IS POWER GOING TO THE BEAMS, IF NOT RESTORE POWER.3. IF SAFETY BEAMS ARE NOT FITTED ENSURE THAT A HARD WIRE LINK IS FITTED BETWEEN TERMINALS 2 & C14. REMOVE SAFETY BEAM WIRES 2 & C1 FROM CONTROL PANEL AND CHECK IF YOU HAVE A NORMALLY CLOSED CIRCUIT COMING FROM THE BEAMS.
WHEN COMMISSIONING GATE AUTOMATICALLY OPENS BUT DOES NOT AUTOMATICALLY CLOSE	<ol style="list-style-type: none">1. MOTOR WIRES ARE WRONG WAY ROUND. CHECK AND PROVE MOTOR DIRECTION BY MOMENTORIALY PULSING TERMINALS 2 & 3. THE GATE SHOULD OPEN UP. TURN AUTOMATIC CLOSING OFF (DIP SWITCH 2) UNTIL MOTOR DIRECTION HAS BEEN PROVED.

PROBLEM	SOLUTION
GATES WILL NOT RESPOND TO REMOTE CONTROL COMMAND	<ol style="list-style-type: none"> 1. AF FREQUENCY CARD NOT FITTED TO CONTROL PANEL. 2. REMOTE CONTROL HAS NOT BEEN PROGRAMMED INTO THE CONTROL PANEL. 3. REMOTE CONTROL HAS THE WRONG CODE SETTING. 4. "OPERATOR PRESENT" HAS NOT BEEN SELECTED TO DEACTIVATE RADIO REMOTE CONTROLS (DIPSWITCH 1). 5. WRONG FREQUENCY CARD FITTED FOR THE REMOTE CONTROL.

IF THE PROBLEM IS STILL APPARENT CONTACT THE CAME TECHNICAL HELPLINE:

0115 921 0430

THIS INSTALLATION WAS COMPLETED BY:	
.....	
NAME.....	
ADDRESS.....	
.....	
.....	
TEL.....	MOBILE.....
DATE OF INSTALLATION.....	

5 - TECHNICAL INFORMATION

5.1 - Technical Specification

GEARMOTOR	WEIGHT	POWER SUPPLY	CURRENT	POWER	DUTY CYCLE	MAX. TORQUE	REDUCTION	TRAVEL TIME	CAPACITOR
FROG A	11 kg	230V a.c	1,9 A	200 W	30%	* 320 Nm	1/1152	18 sec.	16 uF
FROG AV	11 kg	230V a.c	2,5 A	300 W	30%	* 320 Nm	1/1152	9 sec.	20 uF

* Can be adjusted using CAME control panels

5.2 - Casting Dimensions

BOLT FOR REMOVAL &
INSERTION OF M6 GREASE
NIPPLE
(NOT SUPPLIED)

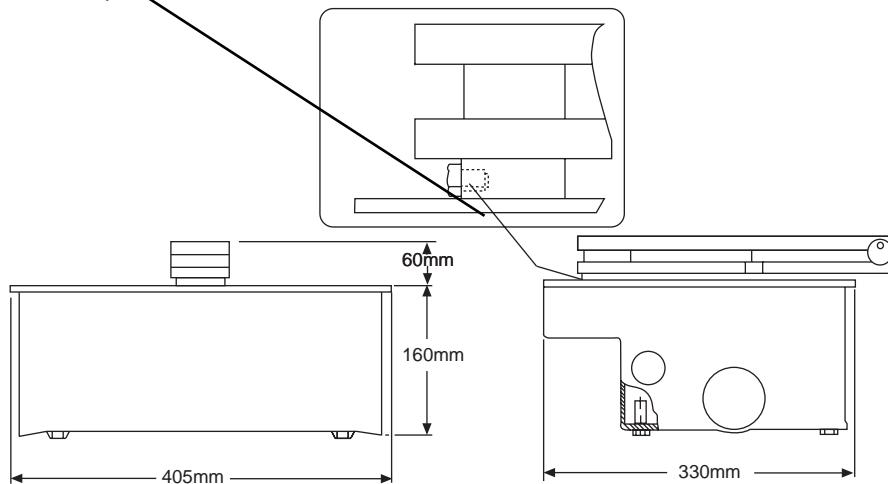

5.3 - Operating Limits

WIDTH OF GATE	WEIGHT OF GATE
2.00 m	800 Kg
2.50 m	600 Kg
*3.50 m	400 Kg

* AN ELECTRIC LOCK IS SUGGESTED WHEN THE GATE WING IS
WIDER THAN 3.5M

5.4 - Motor Torque Settings

SEE ALSO PAGE 14

To vary the motor torque, move the indicated spade connector to one of the four positions : 1=min, 4=max.

N.B. It is always best to start from position one and increase the torque setting as required.

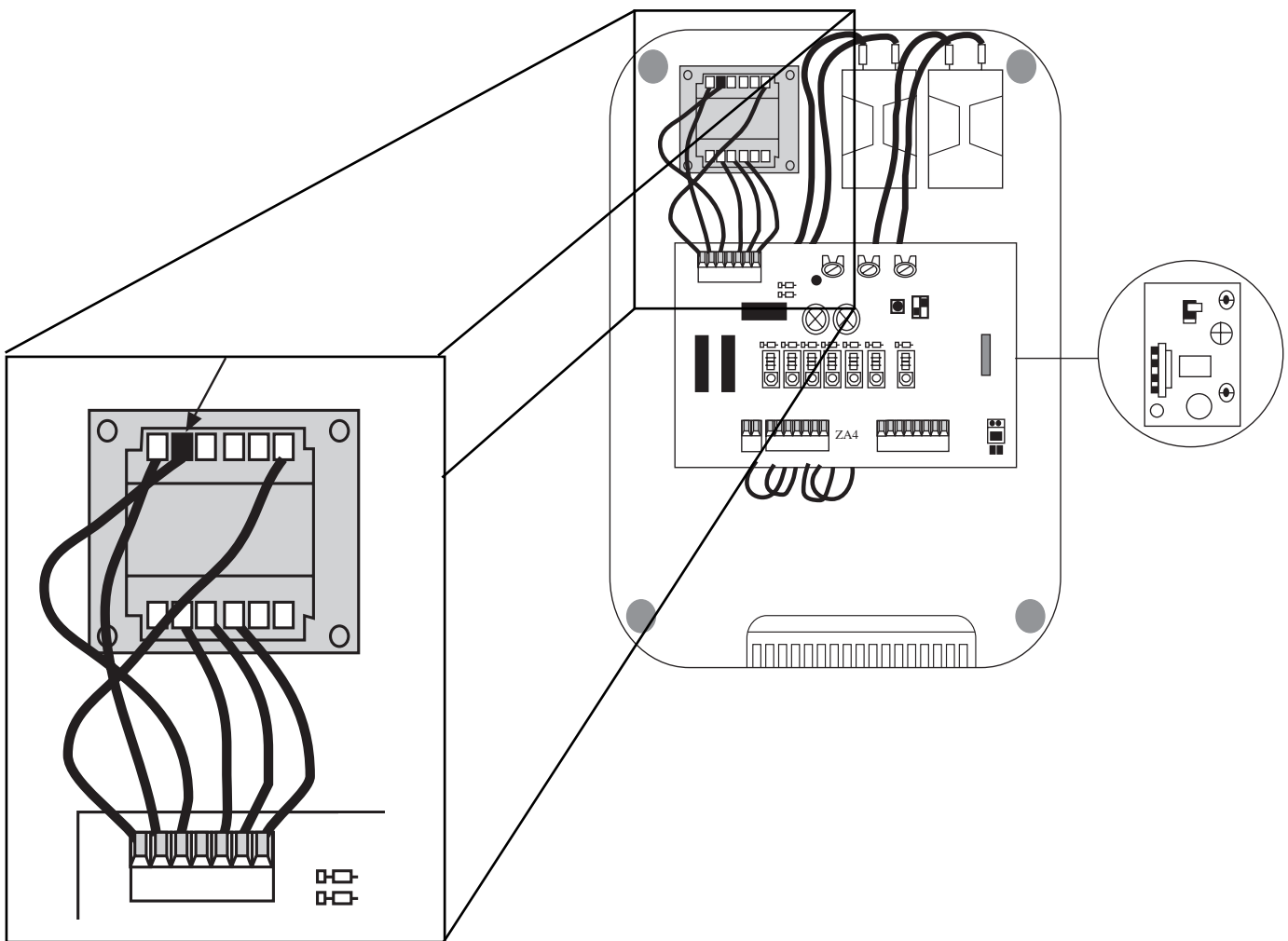

5.4 - Motor Torque Settings

Description of Control Panel:

Micro-processor controlled electrical cabinet powered by 230V (a/c) at 50-60Hz, single phase. Designed for control of CAME (ATI/FERNI/FROG), for hinged gates, hinged industrial doors. Designed and built entirely by CAME to meet UNI8612 safety standards at an IP 54 level of protection. Housing made of ABS is equipped with vents to provide internal air circulation. Guaranteed for 3 years, unless tampered with. This control panel is powered 230V a.c across terminals L1 and L2, and is protected by a 5A fuse on the main power line. Control systems are powered by low voltage and protected by a 2A fuse. The accessories total wattage (24V) must not exceed 20W.

Safety:

SAFETY BEAMS CAN BE CONNECTED TO OBTAIN:

Re-Opening: During closing (2-C1), if the beam is broken while the gate is closing, they will reverse the direction of movement until the gate is completely open and will stay open until the obstacle is removed.

Total Stop: (1-2) Creates immediate stop of gate movement without automatic closing: (a pushbutton or radio remote control must be actuated to resume movement).

N.B IF A NORMALLY CLOSED SAFETY CIRCUIT (2-C1, 1-2) IS OPENED, THE L.E.D WILL FLASH TO INDICATE THE FACT THAT THE BEAM IS BROKEN.

Accessories that can be Connected to this Unit:

“Gate in Motion” Lamp:

The lamp that lights the manoeuvring zone:

it remains lit from the the moment the gate begins to open until they are completely closed (including the time required for the automatic closure).

When automatic closure is not enabled, the lamp remains lit only during movement (E-E3).

Other functions available:

Automatic closing: The automatic closing timer is automatically activated at the end of the opening cycle. The pre-set, adjustable automatic closing time is automatically interrupted by the activation of any safety system, and is deactivated after a STOP command or in case of power failure.

“Operator present” function: Gate operates only when the pushbutton is held down (the radio control system is deactivated)

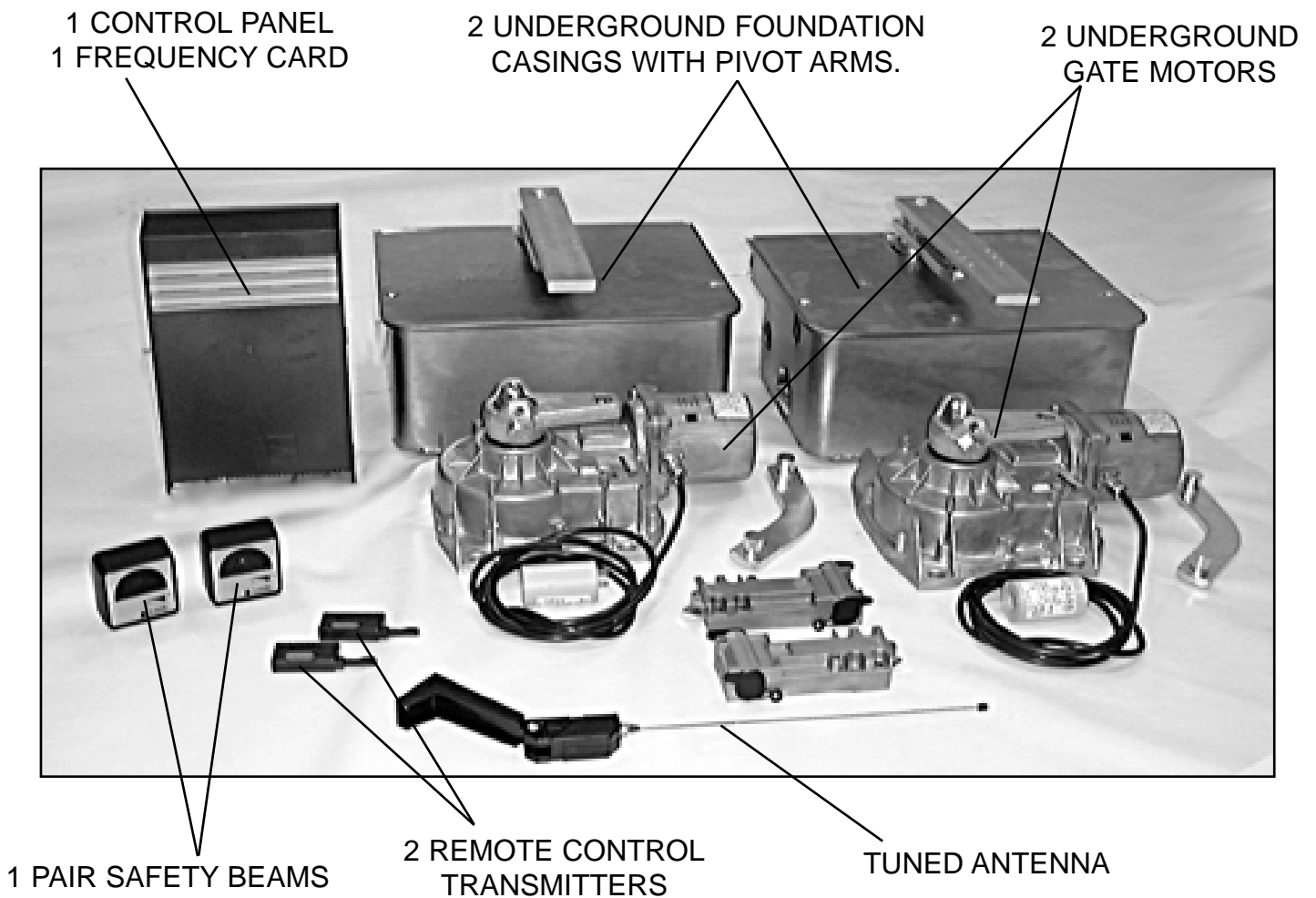

5.6 - ZA4 Wiring Diagram

Terminals 1 and 2, 2 and C1 are normally closed circuits and if they are not used they must be linked

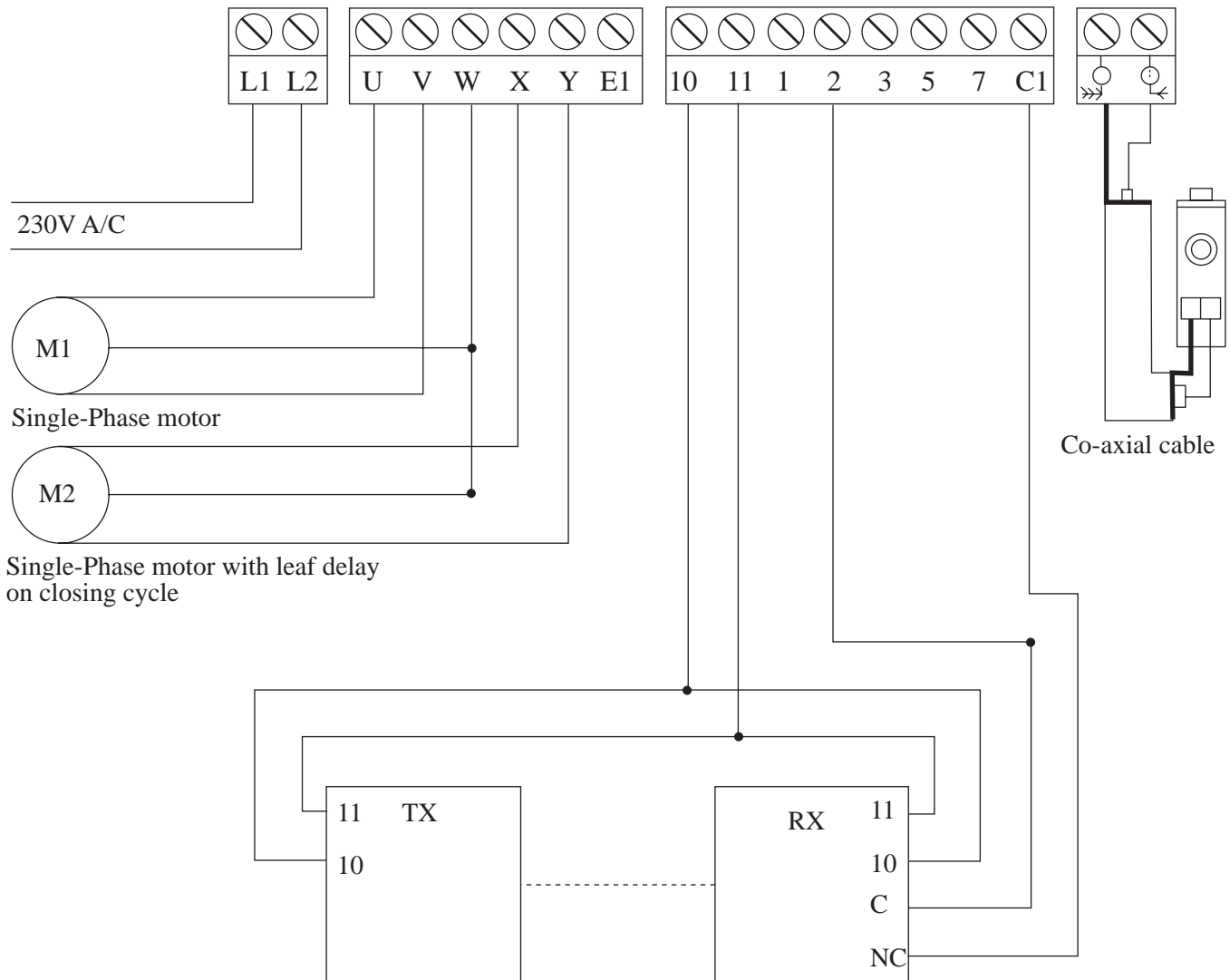

Safety beams which are connected to obtain Re-opening
During the closing cycle

5.7 - Control Panel Adjustments

Trimmer T.L - Adjustment of operating time from a minimum of 0 seconds to a maximum of 120 seconds N.B. it is advised to let the motors run on for between 6 and 8 seconds after the last gate has fully close.

Trimmer T.C.A - Adjustment of automatic closing time from a minimum of 1 to a maximum of 120 seconds.

Trimmer T.R.2.M - Partial opening time adjustment and delay in closing of the second motor leaf delay from a minimum of 0 seconds to a maximum of 20 seconds.

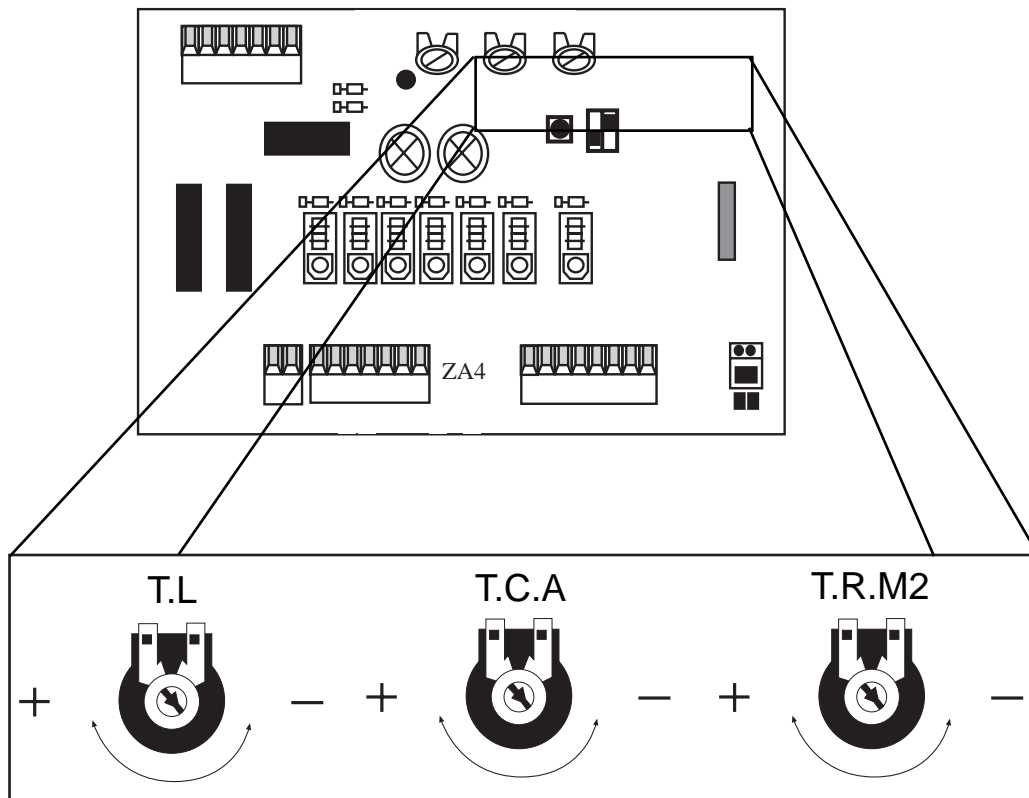

5.8 - Electrical Connections

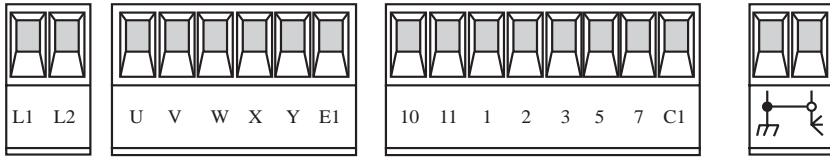

Power supply for control panel

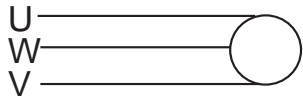

Connection for motor one (delay in opening)

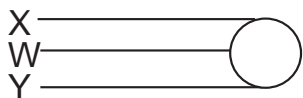

Connection for motor two (delay on closing)

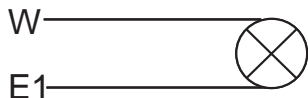

230V (A.C) 25W max output in motion (e.g. flashing light)

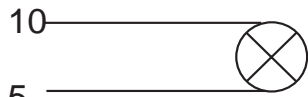

“Gate Open” signal light (24V 3W max)

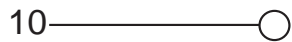

24V (A.C) Output power supply to accessories (max 20W)

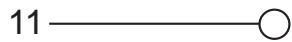

Stop button (N.C)

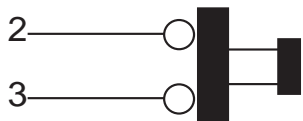

Open only button (N.O)



Contact for radio and or pushbutton control for open-close

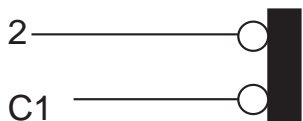

Contact (N.C) for re-opening during closing

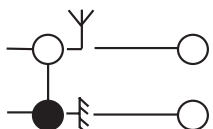

Antenna connection

5.9 - Re-Handing the Frog Motors

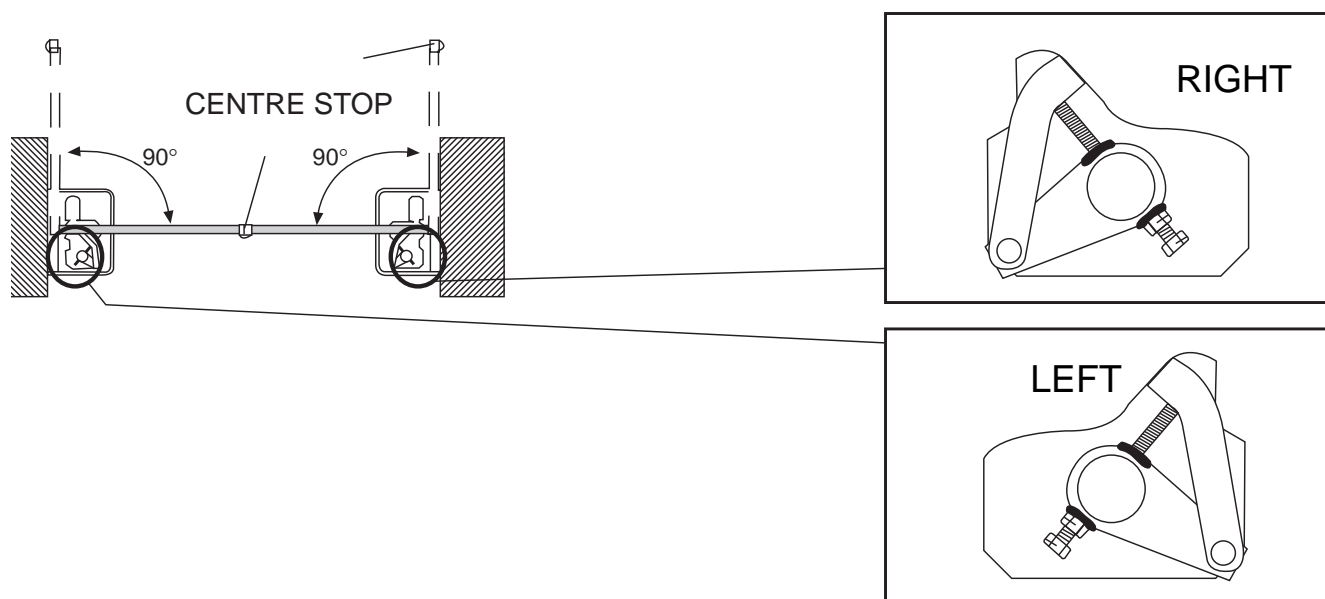

ON RECEIPT YOUR FROG MOTORS WILL HAVE BEEN SETUP FOR YOU AS A PAIR I.E LEFT HAND AND RIGHT HAND BUT SHOULD YOU NEED TO RE-HAND THESE MOTORS THE FOLLOWING INSTRUCTIONS WILL SHOW YOU HOW.

SCREW THE M10 X 100MM BOLT (A) AND THE M10 NUT (B) INTO THE MOTOR TRANSMISSION ARM AS SHOWN IN FIGURE ABOVE. FOR R/H MOTOR INSTALLATION AND FOR L/H MOTOR INSTALLATION SEE FIGURE ABOVE.

ENSURE THAT THE MOTOR IS CORRECTLY FASTENED INTO THE CASING WITH THE NUTS AND WASHERS PROVIDED. INSERT THE LIMIT ARM (C) BETWEEN THE MOTOR TRANSMISSION ARM AND THE FROG SHOE. GIVE THE GATE A COMMAND TO OPEN, WHEN THE GATE COMES TO THE OPEN POSITION AND THEN ADJUST THE SCREW (A).

CLOSE THE GATES SO THAT SCREW (A) MEETS THE LINK ARM. THEN OPEN THE GATE AND ADJUST (A) ACCORDINGLY. DURING ADJUSTMENT ALLOW THE GATE TO PUT ADEQUATE PRESSURE ONTO THE CENTRE STOP BUT ALLOWING THE GATE TO BE RE-LOCKED ONTO THE SHOE AFTER MANUALLY RELEASING THE GATE.

WHEN ADJUSTMENT IS FINISHED FASTEN NUT (B).

NOTES

NOTES

6. INFORMATION



THIS INSTALLATION WAS COMPLETED BY:

.....

NAME.....

ADDRESS.....

.....

.....

.....

TEL..... MOBILE.....

DATE OF INSTALLATION.....